

RAC683031SDG2 Cabinet
Installation and Operations Manual



INTRODUCTION

The purpose of this document is to assist users/installers in the mounting and configuration of the RAC683031SDG2 Cabinet, which is intended to serve as a durable and environmentally controlled enclosure to mount electronics equipment for outdoors deployment and power cell-site radio equipment (BTS's and MCPA's).

Strict adherence to manufacturer's recommended mounting, installation and operations procedures for sensitive electronic loads (radio systems, microwave gear, etc.) must be followed to ensure proper equipment operation, avoidance of damage and maintenance of warranty. In most cases, a certified installer for such equipment will be required.

Purcell Systems, Inc. is not responsible for any equipment damage or poor operating performance when these guidelines are not followed and/or when non-certified installers are used.

NOTE

This document is intended as a general "guideline". To maintain warranties on various equipment installed within this cabinet always reference the specific Installation and Operations Manual for that equipment. Failure to do so may result in lapse of warranty and/or equipment damage. Furthermore, careful attention must be given to conform to jurisdictional codes and construction covenants prior to any site install.

©2006, All Rights Reserved
Originated in U.S.

PURCELL SYSTEMS CONFIDENTIAL:

The information contained in this document is the property of Purcell Systems, Inc., and is to be used solely for its intended purpose as a Purcell product Installation and Operations Manual. Except as specifically authorized in writing by Purcell Systems, Inc., the holder of this document shall keep the information contained herein confidential and shall protect same in whole or in part from disclosure and dissemination to third parties.

This document and any information contained herein may not be reproduced, represented, or downloaded through any means without prior written consent of Purcell Systems, Inc.

The following are trademarks of Purcell Systems, Inc.: Purcell Systems, Inc. and the Purcell Systems, Inc. logo.

All other brand and product names are trademarks or registered trademarks of their respective holders.

Revision History

00	Initial Release	07/14/2006	
Approvals		ME	J.L.
		EE	C.C.

Revision	ECO#	Description of Change	Approvals	
			ME	
			EE	
			Prod. Mktg.	
			ME	
			EE	
			Prod. Mktg.	

I. TOPIC GUIDELINE

A. Site Selection & Mounting Template:	6
B. Unpacking and Preparing for Mounting:	8
C. Accessing Lifting Eyes/Mounting the Cabinet (If necessary):	8
D. Grounding Service Connection:	9
E. AC Power Service Connection (Incoming AC):	10
F. Communications Service Connection (Optional):	14
G. Battery Installation:	15
H. DC Power Plant Setup & Operations:	17
I. Nokia Ultrasite Connections:	17
J. RF Services Connection (Optional):	19
K. Alarm Issues:	19
L. Air Conditioner Considerations:	20
M. Hi-Heat Emergency Vent System (EVS) Details:	20
N. Product Maintenance	22

II. OTHER REFERENCED DOCUMENTS

1200A DC Power Plant "Install, Operations & Maintenance Manual"
Nokia Ultrasite Installation & Operations Manual
Cabinet Air Conditioner Instruction Manual
T-span Surge Protector Installation Guide
Battery Manufacturer Installation Guide

COMPONENT LAYOUT

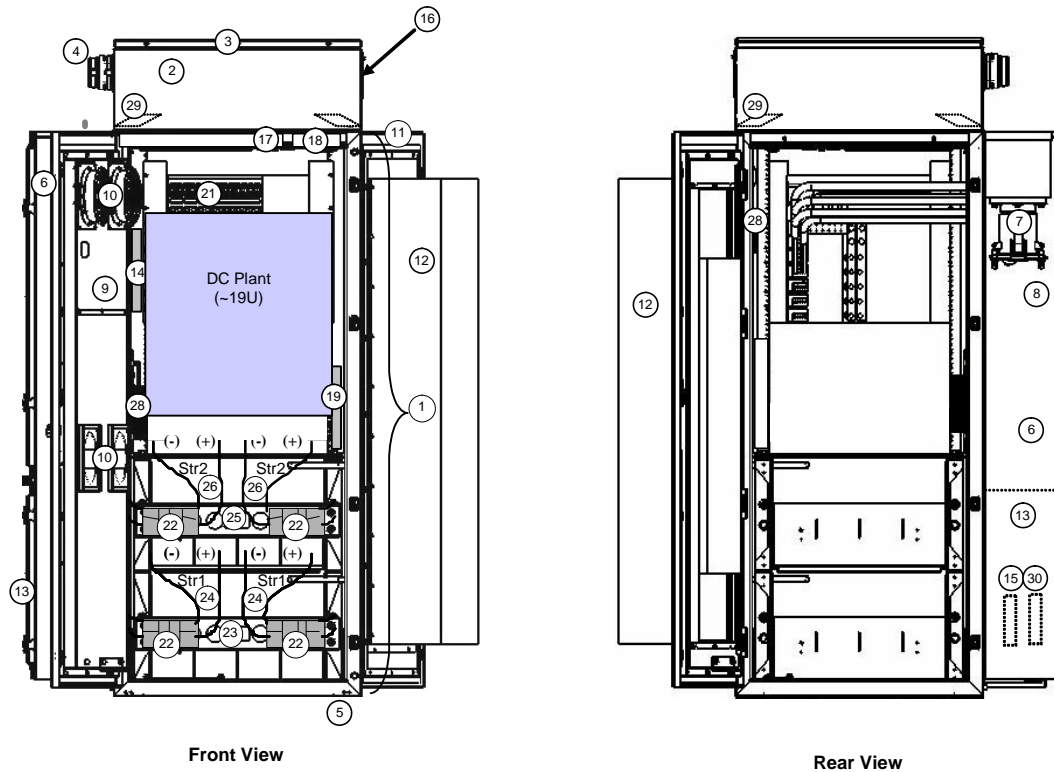

Figure 1 – RAC683031SDG2 Component Layout (+24V Configuration)

- | | |
|-------------------------------------------------------------------------------|---------------------------------------------------|
| 1. Equipment Compartment | 19. Main Alarm Terminal Block |
| 2. Top Compartment | 20. 1200A DC Plant (+24VDC) |
| 3. Top Cap (With Rear Hinges) | 21. DC Load Breakers And PDU |
| 4. 4" Dia. RF Cable Ports (Qty = 4) | 22. Battery Disconnects (Connectors Or Breakers) |
| 5. Plinth (optional) | 23. String 1 and 2 Battery Box And Retaining Bar |
| 6. 240/120VAC, 200A PPC/Term Mod (Bkrs For Recepts, A/C & DC Plant Pre-Wired) | 24. String 1 and 2 Battery Cables And Temp Sensor |
| 7. 200A Generator Inlet | 25. String 3 and 4 Battery Box And Retaining Bars |
| 8. Internal TVSS Modules | 26. String 3 and 4 Battery Cables And Temp Sensor |
| 9. Front Door With Hi-Heat Vent System | 27. 20A AC Power Receptacles (2 Std, 2 GFI) |
| 10. Hi-Heat Emergency Vent System | 28. 30A Junction Box For Rear Air Conditioner |
| 11. Rear Door With Air Conditioner | 29. Lifting Eyes (4x, Accessed From The Top) |
| 12. Air Conditioner | 30. Telco Ground Bar (TGB), Isolated |
| 13. Telco Demark Cabinet, Lower Area Of PPC | |
| 14. Master Ground Bar (MGB), Isolated | |
| 15. Equipment Ground Bar (EGB), Isolated | |
| 16. BTS Cable Port And Cover | |
| 17. Interior Light | |
| 18. Smoke Alarm | |

A. Site Selection & Mounting Template:

The RAC683031SDG2 can be configured to house batteries & equipment in several configurations. The two most common are as follows:

- Mounted on a concrete pad at grade (Greenfield application).
- Mounted on a reinforced surface within an existing structure (e.g. rooftop)

Regardless of configuration, a reinforced mounting pad or I-beam supporting structure is required for the enclosure to prevent the cabinet from shifting or overturning. The pad may require steel rods to prevent cracking and to ensure that the anchor bolts will not be pulled out of the pad. A slab on grade is not sufficient because of the effect of frost heaving on the pad. The pad provides door clearance and a work area around the enclosure. If a larger work area is desired, a slab on grade can be poured around the mounting pad. The slab must be designed and installed in accordance with local building codes.

NOTE

When designing a pad or supporting structure, be sure to account for the maximum weight of the cabinet (~210 lbs. cabinet with AC Demark Cabinet, DC Plant, & 2x Battery Boxes) and all accessory items (power supplies, batteries, etc.) that will be installed (**Typically up to 2000 lbs. with 1000A, +24V DC Plant, 2x Battery Boxes, [8] 170Amp*Hr batteries**). Design the footprint of the pad to accommodate the R81PW-01 Cabinet (and any provided side cabinets) and personnel access (~2'-3' in the front & left for door swing-out) as necessary.

The site should be chosen to avoid these potential situations as well:

- small alcoves that enclose the cabinet on 3 or 4 sides
- small alcoves that receive direct sun in the mid to late afternoon
- any surface within 4 feet (120 cm) of the rear of the cabinet
- hot air exhaust from neighboring buildings/structures
- hot surfaces such as dark asphalt, tarred roofs, crushed rock
- areas with architectural controls or environmental restrictions
- areas prone to flooding

The first five items may cause premature high-temperature shutdown. Small spaces or certain surfaces that receive direct sunlight tend to retain the solar energy resulting in a much hotter microclimate. Hot exhaust from neighboring structures or re-circulated heat exchanger exhaust due to a nearby surface can also result in an undesirable temperature rise above design targets. Heat gain within the cabinet has many dependencies such as site loading and traffic, solar thermal loading, geographical location, time of day, weather, cabinet orientation, surroundings, and external air movement.

Plan the site to meet or exceed the requirements of any local architectural codes, bylaws, or environmental restrictions, if applicable. The cabinet should not be subject to flooding conditions, as the sealing design is not intended for complete or partial immersion in water, mud or debris.

Figure 2 below shows the pad layout for mounting hardware for the RAC683031SDG2 Cabinet. The cabinet can support up to (8) 170Ahr batteries for a combined weight of ~2000 lbs. The bottom area of the cabinet is ~6.45 ft² which means that the pad (or supporting structure) must be designed to support ~310 lbs./ft² minimum:

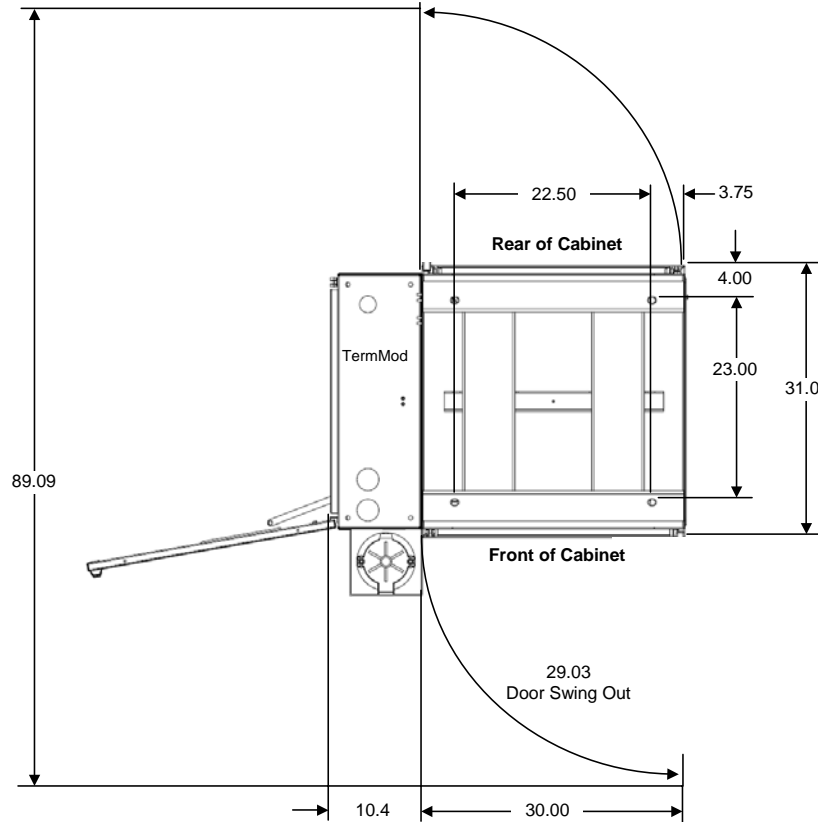

Figure 2 – RAC683031SDG2 Pad Layout. Cabinet with Telco Only option shown

Recommended Minimum Clearances

Top:	12" to allow removal of top caps
Front:	29" to allow for door swing out
Rear:	8" for rear-mounted generator receptacle (0" if Generator Receptacle is removed)
Right Side:	None required
Left Side	Per National Electrical Code (NEC) minimum 36" clearance needed from AC Demark/Distribution panel

1. Pad Install:

For pad install, locate ½" mounting anchors in the pad according to the layout in Figure 2. Section C covers specific instructions for accessing lifting eyes and mounting/securing the cabinet.

B. Unpacking and Preparing for Mounting:

WARNING
Do not lift a cabinet with any optional batteries installed. Once the cabinet has been securely set in place, follow instructions for battery installation.

1. Remove packaging materials to expose the cabinet as mounted on the provided pallet for shipping.
2. The front doors are pad-lockable (padlock provided by end-user).
3. To release the cabinet from the pallet, 4 sets of nuts & washers (at the inside corners of the Equipment Bay) must be removed from provided mounting bolts.
4. Access the front bolts by opening the front swing-out doors.
5. Access the rear bolts by removing the rear hatches and undoing retaining bolts.
6. Retain mounting hardware if needed for future mounting to the pad/support structure.
7. The following table gives cabinet details so it can be determined if lifting apparatus is required for mounting or if standard hand-trucks & dollies may be used: (Verify any transporting equipment is rated for the weights specified)

Cabinet dimensions	77"H x 30"W x 31"D
Cabinet weight(s)	~210 lbs. (Cabinet only) ~80 lbs./Battery Box (can have up to 2 boxes) ~400 lbs. (1200A, +24V DC Plant/Rectifiers) ~100 lbs. (Air Cond.) TOTAL: ~1000 lbs.

C. Accessing Lifting Eyes/Mounting the Cabinet (If necessary):

WARNING
PERSONAL INJURY HAZARD

1. Carefully factor in the combined weight of all materials to be lifted (cabinet, internal equipment, air conditioners, etc.) before engineering a lifting apparatus. A site installation engineer should be consulted to verify adequate support prior to lifting anything.
2. Furthermore, **DO NOT** lift the cabinet with batteries installed. The structure may bend from the excessive weight causing damage to the cabinet and/or the batteries resulting in a potentially hazardous material spill.
3. Carefully follow any installation directions from the manufacturers of installed equipment (radio gear, etc.), which may include populating the cabinet after it has been lifted on site. Failure to do so may result in equipment damage and lapse of warranty.

1. To access the pre-installed lifting eyes to set the cabinet, remove the hardware securing the Top Caps to the cabinet (front retaining screws) and lift them off (See Figure 1).
2. Secure lifting apparatus as necessary to the 4 lifting brackets/eyes.
3. If installing the cabinet on a concrete pad, lay down the ½" thick neoprene pad-gaskets where the cabinet will be placed prior to setting it down to prevent potential corrosive effects. The pad-gaskets are supplied by Purcell Systems.
4. If installing the cabinet on a steel supporting structure, verify the steel is adequately galvanized to prevent possible corrosion with the aluminum cabinet.
5. Once the cabinet is settled over intended mounting bolts, layout seen in Figure 2, secure using appropriate hardware (washers, nuts) as seen in Figure 2.

D. Grounding Service Connection:

1. The various "Equipment Grounds" of the cabinet (DC Plant 0V Buss [DC Return], BTS grounds) system are bonded to the cabinet's Master Ground Bar (MGB) that is accessed on the inside left side of the Power Bay. The MGB is subsequently bonded to an Equipment Ground Bar (EGB) located in the Telco Compartment on the lower left end-cap. (See Figure 3 below, TermMod Shown)
2. All necessary grounds for future equipment to be installed in the Equipment Compartment should be bonded to the MGB (see Figure 3) via 2-hole lugs (5/8" centers, 1/4"x20 stainless steel h/w, lug tongue length to be <1.5").
3. The ground riser from the site "Single-Point Ground" (e.g. buried ring) should be connected to the EGB via CAD-weld to establish the "Equipment Ground." (See Figure 3)
4. For the "Telco Ground," another ground riser from the site "Single-Point Ground" should connect to the Telco Ground Bar (TGB) mounted inside the Telco cabinet. T-span surge suppressors should be grounded to the TGB following provided manufacturer's instructions. (See Figure 3)
5. All other "dead-metal" (cabinet, rack rails, Telco Cabinet, etc.) are bonded to the cabinet frame itself. To tie the "Cabinet Ground" to the site "Single-Point Ground," attach a #2 solid riser with 2-hole lug (5/8" centers, 1/4" dia.) to the external cabinet ground studs located below the front door. Treat the surface with No-ox prior to connection and use appropriate hardware.
6. Grounding of the optional plinth is up to the interpretation of the installation contractor according to customer grounding specifications.

NOTE

Adherence to grounding specifications from equipment manufacturers and end-users is strongly recommended. Failure to do so may void warranties for that gear.

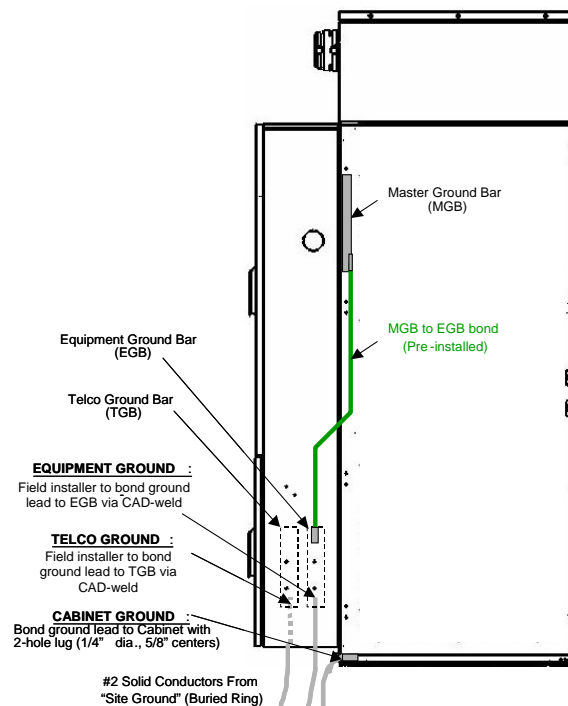

Figure 3 – Grounding Configuration of MGB, EGB, TGB (Power Bay Shown)

E. AC Power Service Connection (Incoming AC):

The cabinet is configured to have the following type of AC Power Demarcation/Distribution:

- The ISATS200 (200A Purcell Protection Cabinet [PPC] w/MTS) from Purcell Systems.



CAUTION

A qualified electrician should perform the procedures listed. The procedures outlined are recommended guidelines; be sure to follow the NEC, CEC (National Electrical Code, Canadian Electrical Code) and local codes. Furthermore, product manuals & labels from manufacturers are enclosed for reference. Refer to that documentation for specific questions on any wiring or labeling.

1. Connection using the ISATS200 Purcell Power Cabinet (PPC)

The following Table gives information on AC power demarcation and distribution:

Pwr Dist Unit	ServiceVoltage (VAC)	Main/Gen Bkr Rating (Amps)	Main BkrAIC Rating	Load-Center Bkr Positions
200A w/ MTS	240/120, 1Φ;208Y/120, 3Φ (2Φ's)	200/200	22,000 Amps	30

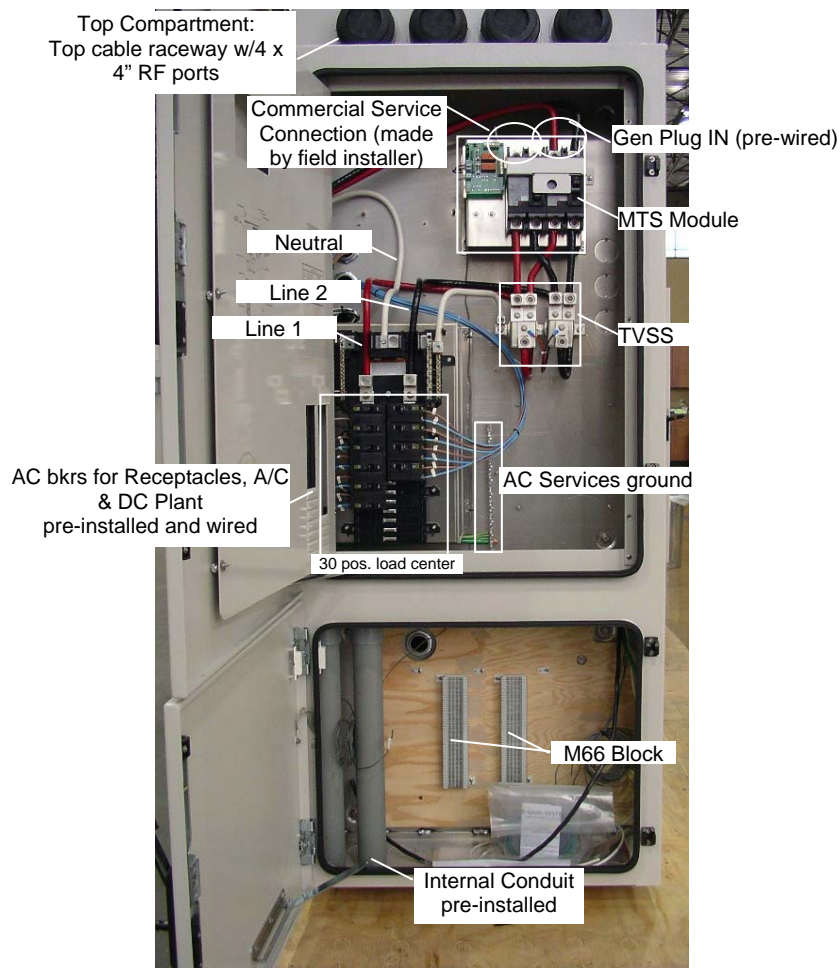

Figure 4 – Left side view showing AC Service equipment (PPC w/MTS Shown)

2. **AC Power Hookup using Purcell Power Cabinet (PPC) Termination Module (TermMod):**

For RAC683031SDG2 cabinets using the PPC for AC power distribution, it is assumed that the site meter is mounted at a remote location and the incoming service is brought to the cabinet in either appropriately sized conduit (see Figure 4) or an overhead drop.

Once the AC service is brought to the cabinet, it is designed to enter from beneath the PPC through either of 2 runs of 2" conduit near the rear of the cabinet. The field contractor must couple to the provided runs that will transport the AC Power Service through the Telco Compartment into the AC Power Compartment (See Figure 5):

- 2.1 Install adequately sized conduit & fittings from the previously installed utility service stub-up area and connect to the provided 2" conduit stubs. The AC metallic conduit can be routed either to the dedicated conduit stub-ups or through a customer-made opening or knock out in an available position in the cabinet.

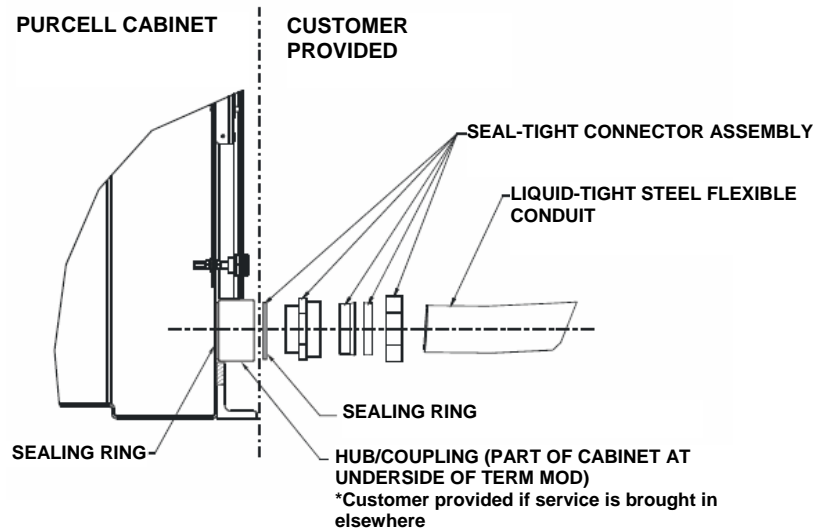

Figure 5 – Conduit Connection Point

- 2.2 The internal connection points can be accessed by opening the PPC's swing-out dead-front.
- 2.3 The two "hot" conductors (Line1 & Line2) should be installed in the "Utility Main Breaker Input Lugs" on the top of the Commercial Main Breaker (see Figure 6, MTS unit shown).
- 2.4 The Neutral conductor (white) should be installed in the large lug position of the Neutral Buss located above the 30-position Load-Center.
- 2.5 The Ground conductor (green) should be installed in an available position on the Ground Buss located next to the Load-Center (see Figure 4). Per Code, the AC Service Ground should be bonded accordingly to a driven rod, etc. by the field contractor.
- 2.6 There is a Neutral-to-Ground Bonding Kit provided in the PPC. The field electrician must install the kit according to the provided instructions if no other Neutral-to-Ground bond exists upline at the site.
- 2.7 Under normal circumstances, the "Manual Transfer Switch" (sliding bar) should have the open end over the left-most breaker allowing the Commercial Disconnect to be ON (see Figure 6).
- 2.8 The electrician should ensure all other breaker, ground & neutral connections are secure & tight before closing up the PPC dead-front & cover.

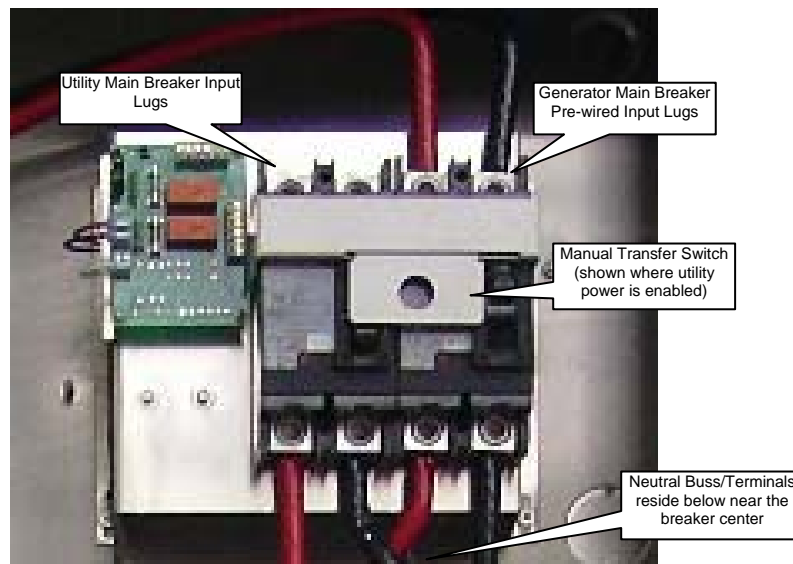

Figure 6 – PPC with MTS Main Breaker Layout (left: Commercial power, right: generator)

3. Generator Operation with MTS Option (refer to Figure 6 for procedures):

During the loss of Commercial power, it may be necessary to switch over to generator power by hooking a generator up to the provided Generator Input on the right side of the PPC. This input is pre-wired to the Generator Main Breaker, Neutral & Ground busses.

- 3.1 Connect portable generator connector to the side input of the PPC (see Generator Receptacle pin layout in Figure 7 below).
- 3.2 Open the front door of the PPC to access the Manual Transfer Switch (it should be positioned so that the blocking "tab" is over the Generator Main Disconnect (right side breaker).
- 3.3 To slide the Manual Transfer Switch to a position where the Generator Disconnect can be turned ON, you must first turn the Commercial Disconnect OFF (slide switch lever DOWN).
- 3.4 Move the blocking "tab" of the Manual Transfer Switch to the leftmost position.
- 3.5 Now the Generator Disconnect can be set to the ON position (slide switch lever UP). This will allow the generator to feed power to the load-center below.
- 3.6 Once commercial power is restored, the Generator disconnect can be set to the OFF position, the Manual Transfer Switch can be moved, and the Commercial disconnect turned back ON.

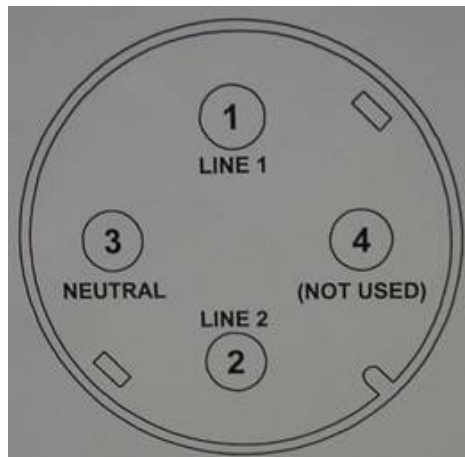

Figure 7 – Generator Receptacle Pin-Out. Verify mating plug matches

4. **Additional Electrical Features:**

4.1 **Utility AC Receptacles:**

There is a dual duplex box on the inside left wall of the front of the RAC683031SDG2 that is wired to a 20 Amp, 1-pole breaker in the PPC. Two of the four receptacles are GFI-protected and can be used by service personnel for misc. equipment.

4.2 **Interior Light:**

On the front of the ceiling of Equipment Bay, there is a DC Powered interior light that can be turned on manually by pressing the rocker switch to ON. Verify the DC Breakers feeding those components are ON for operation).

4.3 **Smoke Alarm:**

There is a smoke alarm installed on the front right corner of the Equipment Bay ceiling. It has a manual test switch and reports a Normally Closed dry-contact alarm.

4.4 **Installing & wiring additional load-breakers:**

QO compatible load-breakers (10kAIC rated) can be installed in the available positions of the Load-Center for future loads (e.g. BTS heater inputs) when the ISATS200 PPC is used. Ensure installation & wiring is performed by a licensed electrician according to NEC and any other related codes.

NOTE

Ensure the power & grounding systems are engineered to meet the specific application as well as local & national electrical codes.

F. Communications Service Connection (Optional):

1. Telco demarcation and provided T-span surge suppression equipment can be mounted inside the optional Telco Demark Cabinet on provided plywood. (The T-span suppressors are provided with and install guide)
2. Bring in service through any of the bottom conduit knock-outs in the Telco Demark Cabinet.
3. Ensure approved conduit fittings are used to maintain a weather-tight seal.
4. Connect incoming Telco lines from previously stubbed-up conduit to the dedicated demarcation equipment (e.g. channel bank, etc.) according to equipment instructions & specifications.
5. There is a small dedicated ground buss inside the Telco Demark Cabinet for grounding installed equipment and any surge suppression (Refer to the provided installation manual for the optional Surge Suppressors for details on mounting, grounding, and maintenance).

NOTE

Strict adherence to installation & grounding specifications from equipment manufacturers is strongly recommended. Failure to do so may void warranties.

G. Battery Installation:

CAUTION

Installation or maintenance of batteries should be done by qualified personnel because of potential exposure to harmful DC voltages and chemicals if batteries are misconnected or damaged. The batteries should always be disconnected (Quick-Connects or breakers) when working on them. In addition, careful attention should be given for proper battery polarity connection. Failure to connect batteries correctly could result in injury to personnel from arcing and damage to the DC rectifiers and any connected equipment that may void its warranty. Batteries are very heavy so extreme caution should be exercised when handling.

The RAC683031SDG2 has 2 battery boxes located at the bottom of the Equipment Bay that can accommodate 150-170 Amp*hr strings per box (shipped separately) of Valve-Regulated Lead Acid (VRLA) batteries (1 string = 2x12V batteries for 24V systems). Table one below shows the batteries that can be installed into the provided battery boxes. Furthermore, battery cables are pre-connected to the DC Power Plant making hook-up fast and easy.

Table 1 – Battery Information

Manufacturer	Model	Model Number	Ahr Rating	Dimensions (L x W x H)	Weight (lbs)
Battery Corp	BC	BC-12V170FT	170	21.97" x 4.92" x 12.2"	106.2
Deka	Unigy 1	12AVR-150ET	150	22" x 4.9" x 11.75"	115
Enersys	Powersafe	12V155FS	155	22.1" x 4.9" x 11.1"	125.6
Fiamm	Monolite	12UMTX170FT	170	16.55" x 6.81" x 10.03"	132.3
GNB	Marathon	M12V155FT	155	22" x 4.88" x 11.14"	118.6
Northstar	NSB	NSB170FT	170	22.05" x 4.92" x 12.6"	131.2

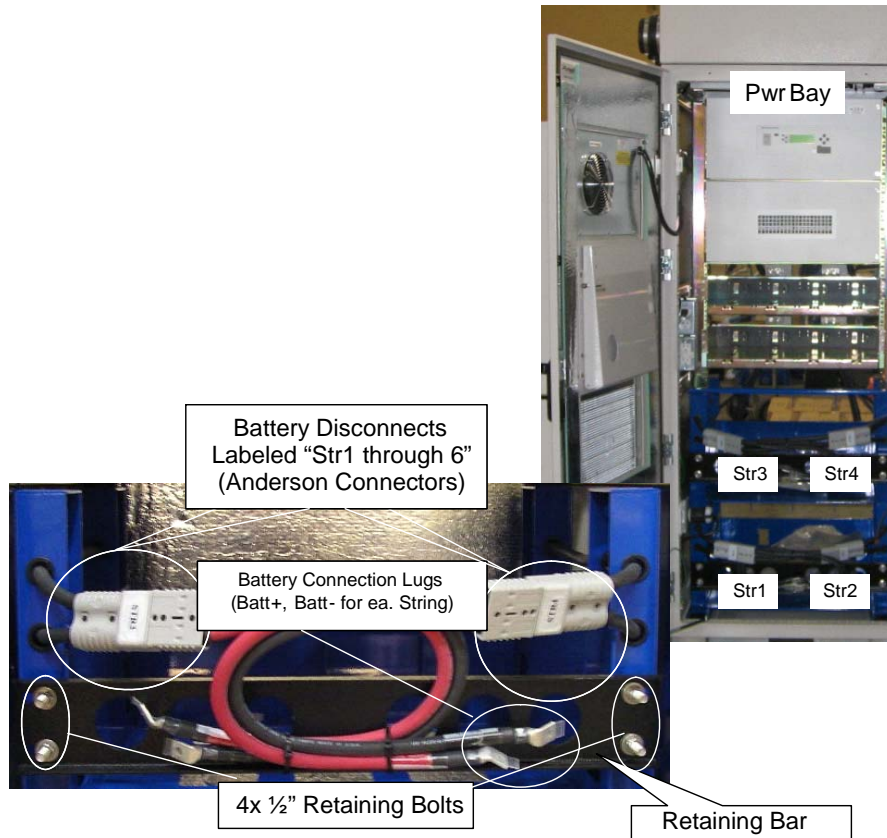

Figure 8 – Battery Install Diagram (+24V Configuration)

1. Open the door of the Bay where batteries are to be installed after it has been secured in place.
2. **Make sure the batteries are disconnected/isolated from the DC Plant and each other by opening the front Battery Disconnects.**
3. At initial installation, any equipment (rectifiers, etc.) located in the battery trays need to be removed and stored in a safe location. Further, any obstructions (Air Cond power cord, etc.) should be moved and then put back in place after batteries are installed.
4. Remove the front retaining plates for each box where batteries are to be installed by loosening the (4) bolts holding them in place with a 1/2" socket or wrench. Retain those parts for reinstall.
5. Move the battery cables and other obstructions out of the way during battery install.
6. The batteries should be placed so there is ~ 1/2" gap between them. Start from the bottom (Strings 1 & 2 for 24V).
7. The battery connection cables come pre-crimped with a 1-hole lug to connect to the (-) terminal of the left-most battery and (+) terminal of the right-most battery for each string (See Figure 8). For safety, they have insulating heat-shrink over the metal lugs. For each string of batteries to be installed ONLY, strip off the insulation covering the metallic lug on the battery cables.
8. Once the lugs are exposed, connect the "BATT+" cable (red) to the (+) terminal of the right battery.
9. Next, connect the "BATT-" cable (black) for String 1 to the (-) terminal of the left battery. (See Figure 8).

Connect battery cables to right & left batteries before any intercell connectors are installed

10. Install intercell connectors across the battery string ([+] terminal of left battery to [-] terminal of adjacent battery to the right). **NOTE:** When the last intercell connector is attached, there may be a slight spark. This is normal operation.
11. If additional strings of batteries are to be installed, follow steps 7-10 above for those strings.
12. When all batteries are installed, re-engage the front Battery Disconnects to electrically connect the battery strings to the DC Plant.

H. **DC Power Plant Setup & Operations:**

The "Installation & Operations Manual" for the 1200Amp DC Power Plant comes with every RAC683031SDG2 cabinet in the laptop tray/document holder. It is strongly recommended to refer to that manual for specific instructions regarding operation and programming of the plant.

1. Pre-Integrated DC Loads (Installed by Purcell Systems):
 - 1.5 The Emergency Ventilation System (EVS, more details in Section M) pre-wired to a 10A DC Breaker in the DC Shelf.
 - 1.6 DC-powered Lights fed from the same 10A DC Breaker as EVS.
 - 1.7 DC-powered Smoke Alarm is fed from a 5A DC Breaker.
 - 1.8 10-Position GMT Fuse Distribution Block fed from a 50A DC Breaker.
2. Connecting Future DC Loads (Performed by Qualified Technician ONLY):
 - 2.1 Future DC loads can be installed in any free 23" rack space and wired from available breaker positions.
 - 2.2 Follow the appropriate section in the DC Plant Installation Manual for installing load breakers into any of the available positions and wiring to the loads.

I. **Nokia Ultrasite Connections:**

Purcell Systems' RAC683031SDG2 is designed to power several Nokia Ultrasites (and other accessory cabinets [MCPA, UMTS, etc.]) that can be configured in a variety of ways. The core cabinet lineup can grow to the right (as seen in Figure 9).

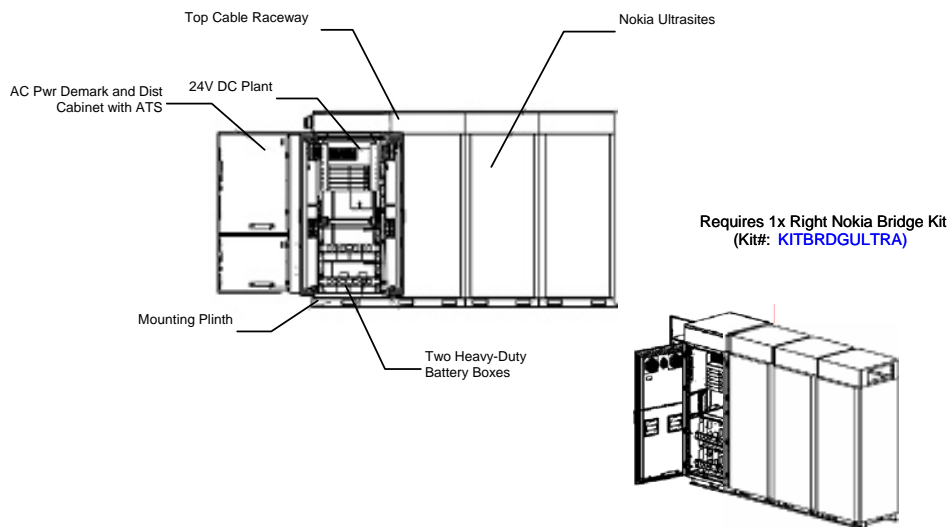

Figure 9 – Cabinet Lineup Growth to the right (Lineup shown with optional plinths)

1. **Growth to the right:**
When growing the cabinet lineup to the right, it is recommended to use the KITBRDGULTRA cable-port "bridge kit" from Purcell Systems to create a weather-tight interface to the adjacent Nokia Ultrasite (See Figure 9). Please refer to the appropriate Installation Document for that kit for complete details.

2. **Routing Power/Alarm Cables to Adjacent Ultrasites:**

- 2.1 Remove the Top Caps (left & right) of the RAC683031SDG2 to gain access to the two 3-Port Cable Routing Plates.

NOTE

It is the customer's responsibility to make sure any cable ingress through the top 4" dia. ports is watertight based on local practices (rubber compression inserts, butyl tape wraps, spray-in foam, etc.)

- 2.2 The 4" dia. Cable Ports come equipped with Dust Covers. To route Power, Data or Alarm cables through those ports, cut an "X" pattern opening for the cables in the Dust Cover and route them through. Verify ingress point is weather tight with the use of butyl tape or spray-in foam. If the dust covers are removed, ensure that edge grommeting is placed around the perimeter to alleviate chaffing of pass through cables as shown in Figure 10.



Figure 10 – Dust cover and edge grommet

- 2.3 It is recommended that the installer supply and install cable ties or some other kind of strain-relief for those cables.

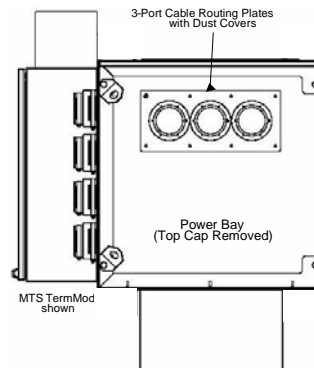

Figure 11 – Top view with top caps removed

WARNING

If moving or accessing the BTS power cables, verify that the corresponding DC breaker and battery disconnect on the DC Power Plant in the Equipment Compartment of the RAC683031SDG2 is in the OFF position. Failure to do so may result in personnel injury or damage to equipment. Work should be done only by a qualified technician.

J. RF Services Connection (Optional):

The 4" diameter "Cable-Entry Boots" situated on the top left side of the RAC683031SDG2 (See Figure 1) can be used to route RF coaxial cables and other data lines.

1. If RF Lines do not exit out of the rear of the Nokia Ultrasites, configure the cables to route through the Top Compartment of the RAC683031SDG2 and out the appropriate 4" dia. RF port in the left side of the cabinet.

NOTE

It is the responsibility of the site installer to provision strain-relief & cable-supporting structures (ice bridges, etc.) before attaching the RF cables to the RAC683031SDG2 Cabinet.

2. Mount any optional coaxial interface connectors (in-line surge suppressors, etc.) or feed-through hardware in the RF port. Ensure all installation and grounding practices are followed according to manufacturers' instructions. Failure to do so may compromise performance or void warranties.

K. Alarm Issues:

There are various "Cabinet System" related alarms, which are FormC Normally Closed (Open on alarm) relay contacts. The following table lists those that are available and are pre-routed to an Alarm Collection Block by Purcell Systems (M66 block in the Telco Box of the TermMod):

#	Description	Conditions
0	AC Power Fail	Commercial power has failed.
1	24V Power Fail	>1 rectifier fails. DC Power capacity compromised
2	Low DC Voltage	Output DC Power below user-defined set point
3	High DC Voltage	Output DC Power above user-defined set point
4	Door Open	Front or rear door open on the RAC683031SDG2
5	Ambient High Temp(Optional)	RAC683031SDG2 Internal cabinet temp above user-defined set point (default 110degF)
6	HVAC Alarm	Air Conditioner malfunction
7	Smoke Alarm	Smoke Alarm activated
8	Hi-Heat Alarm	Hi-Heat System ON
9	AC TVSS Failure (when available)	Blown surge suppression module or AC power failure

Table 2 – List of "Cabinet System" Alarms with Descriptions

All alarms are "Normally Closed" (NC) dry-contact relay states. An "Open" condition constitutes an alarm.

1. **M66 Alarm Collection Block details:**

- 1.1 The M66 Alarm Collection Block will be mounted to the plywood Telco backboard inside the Telco Cabinet (See Figure 1).
- 1.2 The alarm signals referenced in Table 2, previous page, are routed to the M66 block, labeled, and left with enough lead-length to punch as needed. Because of the risk of wires loosening during the vibration of transportation, they should only be punched at their final installation point.

L. Air Conditioner Considerations:

An air conditioner is mounted on the rear door of the Equipment Bay in the RAC683031SDG2 cabinet to regulate internal cabinet temperatures. The thermostat to control the A/C turn-on point is accessible by removing the outer cover & screen filter on the unit. Its default turn-on point is 78°F. This can be adjusted by using a flat-head screwdriver to rotate the set point screw clockwise (colder) or counter-clockwise (warmer). Approximate temperature settings are around the circumference of this control knob. It also has a 500-Watt internal heater for use during colder months designed to turn on at 40°F. This turn-on point is not adjustable.

Checking and cleaning the unit's air filters are critical for its operation so those steps should be added to any Preventative Maintenance (PM) plan where the cabinet is deployed. Each cabinet has the corresponding "Installation & Operations Manual" for the attached air conditioner included in the laptop tray/documentation holder. Please refer to that manual for specific information related to that product

The air conditioner is 230VAC powered and is designed to plug in to a 20A twist-locking receptacle near the center are of the cabinet. Ensure that the unit is plugged in & locked and that the corresponding 20A, 2-pole breaker in the load-center is turned ON for operation.

M. Hi-Heat Emergency Vent System (EVS) Details (optional):

Figure 12 below shows the components of the Hi-Heat Emergency Vent System, which is located on the front door of the Equipment Bay. Both the upper exhaust (fan evacuated) and lower intake ports feature compression-sealed dampers to maintain the environmental integrity of the cabinet when the internal cabinet temperature is below the turn-on threshold controlled by the **BLUE** thermostat knob. Once that threshold is exceeded (indicating an emergency situation like AC Power or Air Conditioner Failure, the system draws DC power from the batteries to run the fans to cool with ambient air. The **RED** thermostat knob controls the set point at which a Normally Closed dry-contact alarm (Open on alarm) is asserted for remote monitoring of a high-heat situation.

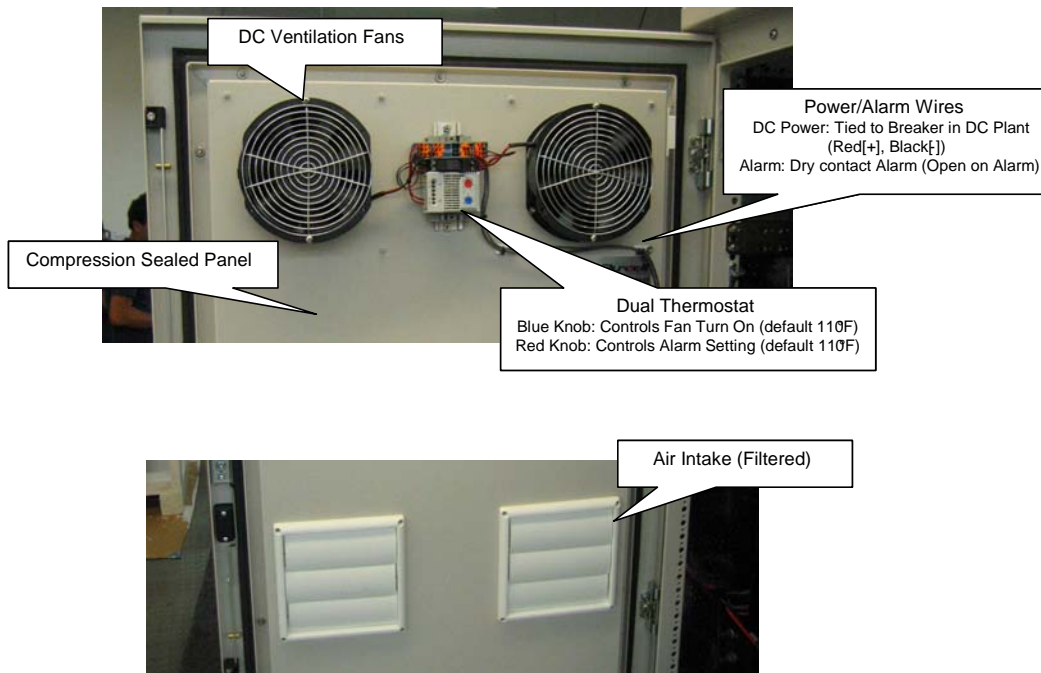

Figure 12 – Hi-Heat Emergency Vent System (EVS) Layout

1. **To Test Fan & Damper Operation:**

- 1.1 Verify the DC Breaker feeding the EVS to test is in the ON position and that 24V power is available either through rectifier or battery power.

NOTE

The EVS is +24V powered. Verify correct polarity so that the + DC power terminal connects to the RED feed wire.

- 1.2 Using a small flat-head screwdriver, rotate the **BLUE** knob counter-clockwise until the set point is below the ambient temperature.
- 1.3 You should hear the relay click engaging the DC fans and causing the motors to open the intake & exhaust dampers.
- 1.4 Once system operation is verified, rotate the **BLUE** knob clockwise until the system shuts off and adjust the set point back to the factory default of 110°F.

2. **To Test the Alarm Transport:**

- 2.1 Using a small flat-head screwdriver, rotate the **RED** knob counter-clockwise until the setpoint is below the ambient temperature.
- 2.2 The alarm contacts at the thermostat & the main alarm terminal block of the Power Cabinet should change from a "Closed" state to an "Open" state.
- 2.3 Once system operation is verified, rotate the **RED** knob clockwise to the factory default of 110°F. You should see the alarm state change back to "Closed."

N. Product Maintenance

The RAC683031SDG2 cabinet maintenance list is to be used in conjunction with local preventative maintenance plans already in use. Frequency of such practices is up to the customer based on local environmental conditions but it is recommended that they be followed at least once every 6 months.

1. **Cleaning Filter on Air Conditioner:**

- 1.1 For information on the thermostat control to test the air conditioner refer to the Air Conditioner Considerations Section.
- 1.2 To access the intake filter, locate the air conditioner inlet grill towards bottom of unit.
- 1.3 Remove the two Phillips head screws attaching the grill to the unit (See Figure 13).



Figure 13 – Inlet grill of Air Conditioner

- 1.4 Pull the top edge of grill forward to access the filter.
- 1.5 Now that the filter has been removed it can be cleaned with the following steps:
 - a. Flush filter with clean warm water through the exhaust side towards the intake side. **Do not use any chemicals.**
 - b. Place the filter corner down and allow it to drain.
 - c. Using RP Super Filter Coat adhesive, recoat both sides of filter.

2. **Smoke Alarm/Light Testing**

Using the manual test button, check smoke alarm for proper operation. Testing the light fixture by this method is also recommended.

- 2.1 Open the front door. On the top right side you will see the smoke alarm.
- 2.2 Press and hold the test button on the smoke detector until an audible sound is heard

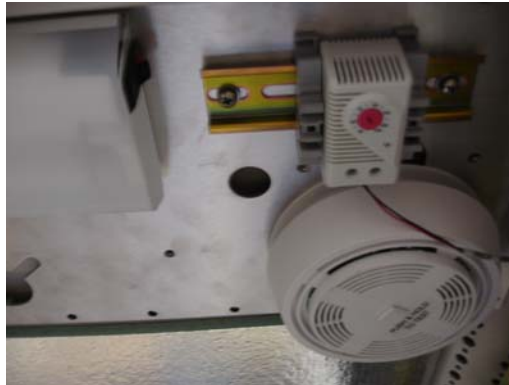

Figure 14 – Smoke Alarm and Light Fixture

- 2.3 Next to the smoke alarm there is a light with a manual turn-on switch. When checking the smoke alarm, it is recommended to test the switch and light as well.

3. **Transient Voltage Suppression LED Check:**

- 3.1 Open top door of side mounted PPC.
- 3.2 The TVSS LEDs are located to the left of the MTS (See Figure 15).
- 3.3 With AC-Powered **ON**, look at the led's to verify that they are lit.

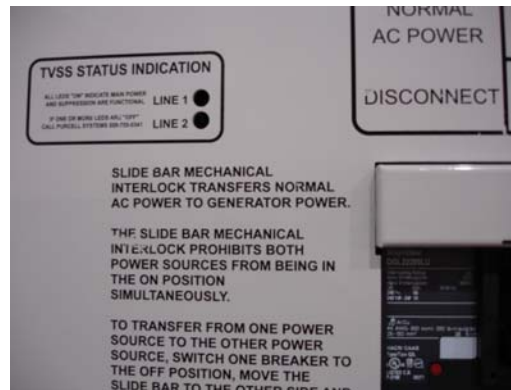

Figure 15 – TVSS LEDs next to the MTS

4. **Checking for Adequate Draining in Top Compartment:**

- 4.1 Remove the 3 screws holding on top plates as shown in Figure 16.
- 4.2 To remove the cover, lift up on front and slide the lid back one to two inches. Lift the lid off of the cabinet (see Figure 17).
- 4.3 Reach down into top and check the corners of the RF top for adequate drainage (see Figure 18).



Figure 16



Figure 17



Figure 18

5. **Verify that the generator plug cover is secured properly:**

- 5.1 Check that wing nuts are snug and lid fits completely over the end of the receptacle.



Figure 19 – Generator plug and cover

6. Test fan and damper operation on Hi-Heat EVS; clean/replace filters as needed:

To test fan and damper operation refer to the Hi-Heat Emergency Vent System section.

- 6.1 To replace filters, start by opening the battery bay door
- 6.2 Remove the four mounting screws that hold the housing to the door (see Figure 20).
- 6.3 Pull the housing away from door, exposing the filter (see Figure 21).
- 6.4 Lift the filter off of the three mounting tabs that hold the filter (see Figure 22).



Figure 20



Figure 21



Figure 22

Sales Office Information

All inquiries for purchasing Purcell Systems enclosures should be directed to your Purcell Sales representative:

(877)755-0341

Purcell Systems, Inc.
16125 E. Euclid
Spokane Valley, WA 99216
Fax (509)755-0345
Email: info@purcellsystems.com

Technical Information

Please contact Purcell Systems, Inc. Technical Support for any additional information:

(509)755-0341

Purcell Systems, Inc.
16125 E. Euclid
Spokane Valley, WA 99216
Fax (509)755-0345